



Qbitus Products Direct – Order Form

Qbitus Products | Springwood Cornmill | Rawroyds | Holywell Green | Halifax HX4 9ED
 Tel 01422 377775 | Fax 01422 311750 | Email sales@qbitus.co.uk | Web www.qbitus.co.uk

Qbitus is a registered preferred supplier to the NHS and is the United Kingdom's leading supplier of bespoke pressure relieving and positional medical cushions.

Each product made by us is expertly handcrafted, in our manufacturing department in Yorkshire, to your own personal design and specifications or as one of our standard products such as the Community 1 cushion.

Whilst Qbitus guarantee the quality of materials used and the expert finish of the handmade product, private clients must recognise that we work strictly to the design given to us. This means we rely entirely upon these measurements to make the product – therefore, accuracy in the dimensions you provide regarding your specific requirements is essential.

The diagrams below may help you to produce your measurements. Metric or imperial measurements are acceptable to us when you submit your order.

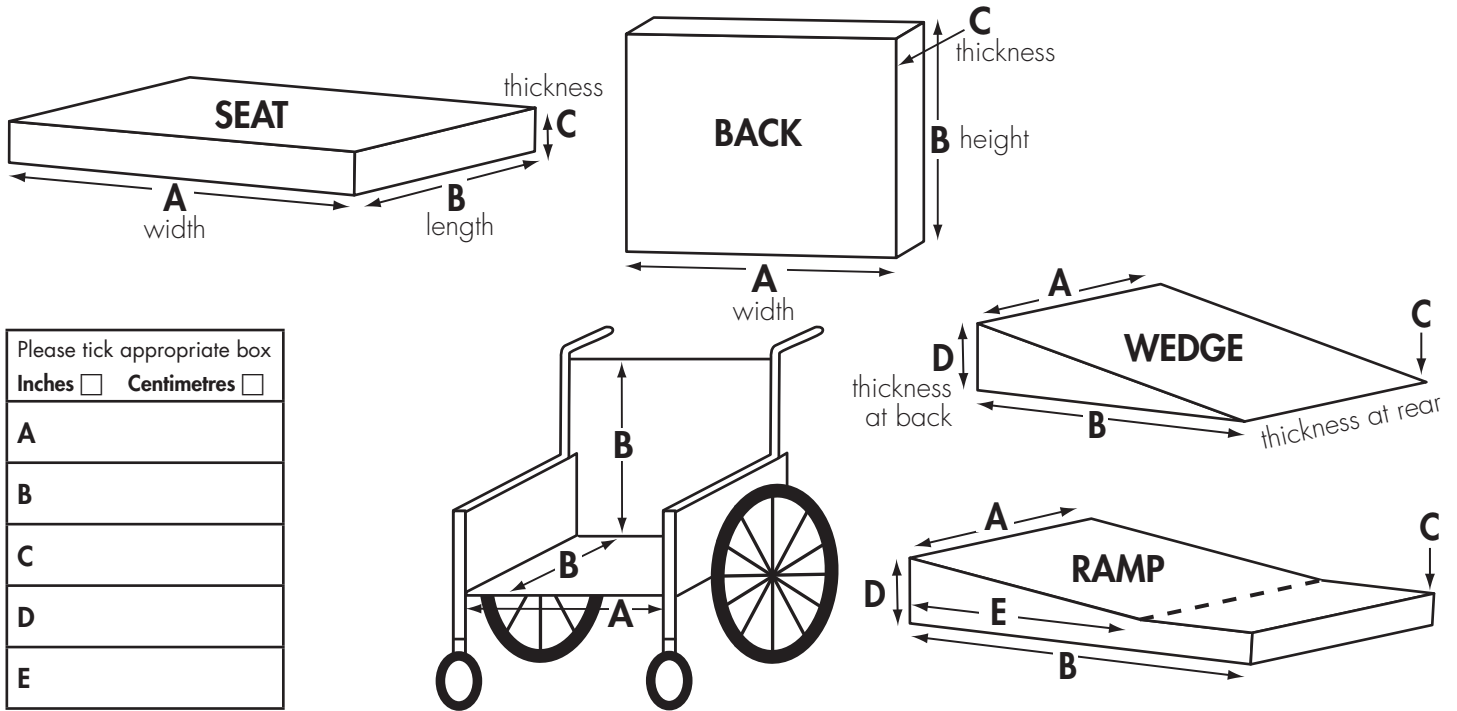

Please tick appropriate box
 Inches Centimetres

A
B
C
D
E

All cushions include an inner waterproof liner and non-slip base. You have a choice of outer cover; either terry towelling (100% polyester) or vapour permeable, which is water resistant, soft and breathable. Comes in black or navy blue.

We produce a range of off-the-shelf cushions to choose from:

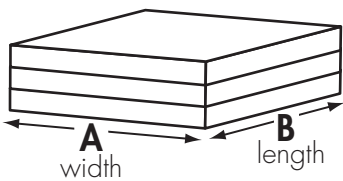

3" Community Cushion

Community 1
 Low/Medium Risk

Community 2
 Medium/High Risk

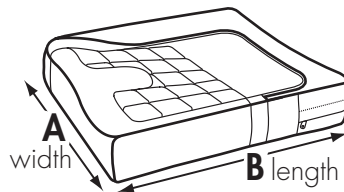

Moulded Shaped Cushions

Mercury 50/100/175
 Medium/High Risk

Interum High Risk

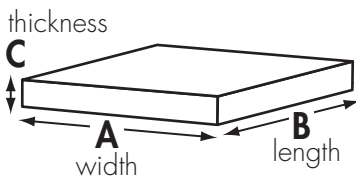

Dynamic Range

Sunmate
 Medium/High Risk

Pudgee
 Very High Risk

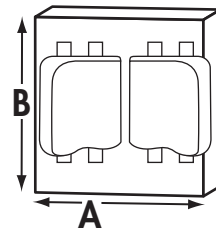

Lateral Support System

Pads come with Velcro for adjustment

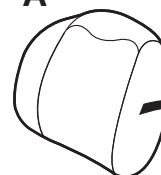

Posture Backrest

Memory foam shaped to add comfort and stability (Universal fit)

All cushions can have tie tapes or Velcro added for securing into the chair.

Qbitus also sells a range of memory foam mattresses, with or without an outer cover.

We only use A-Grade furniture and high quality memory foams in our products, all of which comply with the strictest fire and health regulations.